

Separator and Posi-Flo™ Automatic Suction Control

- **Maximum Efficiency**
- **Minimum Maintenance**

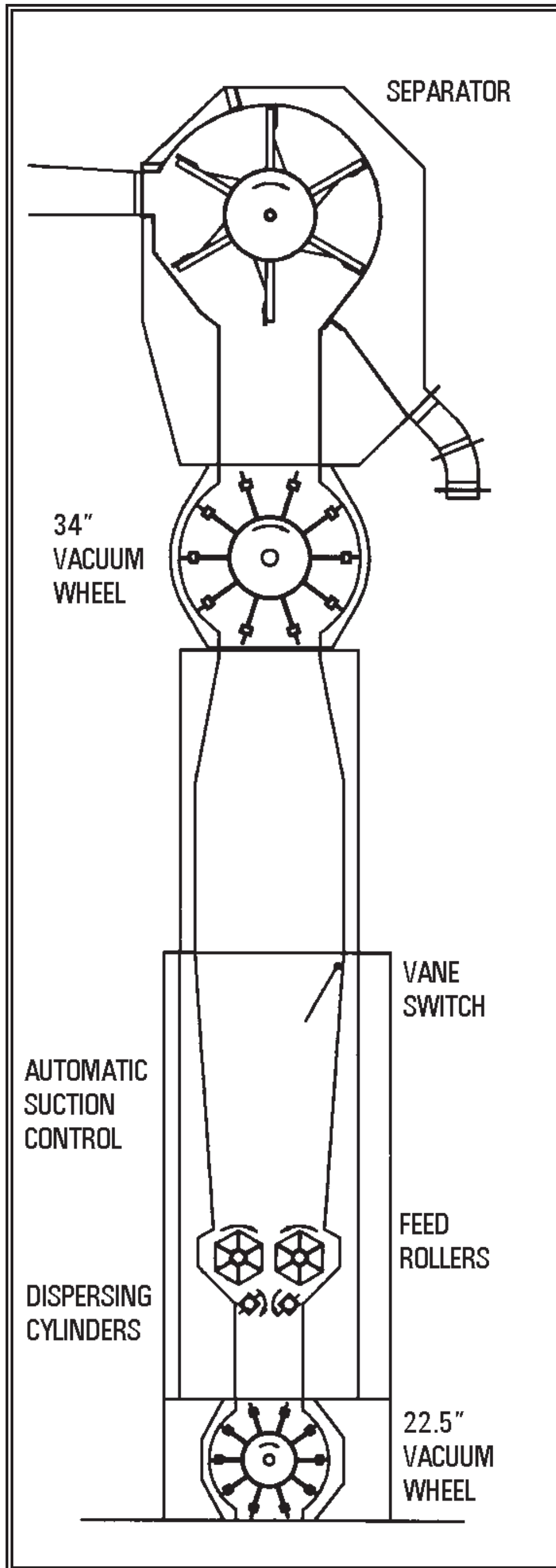

Separator mounted over Automatic Suction Control

Separator

- Removes sand, dirt, pepper trash
- Disperses lumps and wads
- Wiper seals on drum arms keep screen clean
- Available in 96-inch and 120-inch Unloading and 72-inch Overflow models

Posi-Flo™ Automatic Suction Control

- Increases gin efficiency
- Provides uniform flow of seed cotton into the ginning system for maximum cleaning and efficiency
- Heavy-duty feed rollers
- Fingertip control assures uniform flow of cotton through ginning system
- Two dispersing cylinders break up seed cotton into small clusters for maximum exposure and trash removal (on 96-inch model)
- Vane switch detects cotton level for automatic control of incoming feed to the gin
- Free-standing model available in 96 and 120-inch widths
- A 120-inch-wide model is specially designed to fit under module dispersers
- A 120-inch-wide Double Posi-Flo™ allows for complete split-stream operation

10-Flight Vacuum Wheel

- Longer flashing life
- Pivoting Front Scroll allows for easy maintenance
- Better seal reduces air loss
- Six flashing strips in contact with side walls at all times
- Reduced downtime
- Sealed bearings, protected from heat and abrasive dirt
- Direct-drive with C-Face Reducer
- 22.5-inch or 34-inch diameters

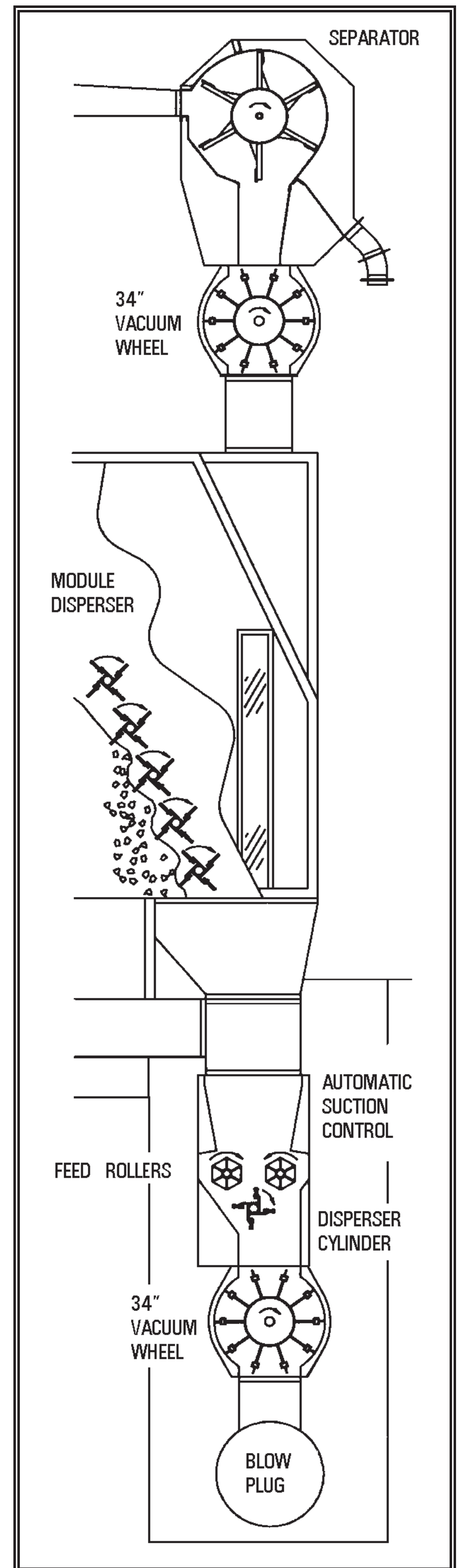

Separator mounted over module disperser with Automatic Suction Control below



Physical Address: 225 Bourne Boulevard • Savannah, Georgia 31408-9586 USA
 Mailing Address: P. O. Box 929 • Pooler, Georgia 31322-0929 USA
 Phone: (912) 447-9000 • Fax: (912) 447-9250
 Toll Free (USA Only): 1-800-4LUMMUS (1-800-458-6687)
 Web Site: www.lummus.com • E-mail: lummus.sales@lummus.com



Lummus products described or listed in this publication are illustrative only. Application and use of these products must be in accordance with the applicable codes and regulations and must be arranged and/or provided with covers and other guards where necessary to assure the safety of personnel. Lummus engineers continue to make improvements. All designs, specifications, and ratings are subject to change without notice.