

Model 86 & 108 Saw-Type Lint Cleaners

Lummus Model 86 & 108 Lint Cleaners provide greater performance than competitive models.

Easy Access

- Doors fitted with electrical and mechanical interlocks.
- State-of-the-art safety devices.
- Large, thermo-formed guard doors allow access to the drives for routine maintenance.

Versatility

Lummus Lint Cleaners allow a variety of arrangements: single, tandem, battery, with or without Super-Jet® Cleaners. The patented Lummus Five-Way Option Valve allows a choice of five different modes of operation.

Solid Steel Key Parts for Precision Lint Cleaning

- Cotton enters the condenser through self-cleaning inlet, using full screen area for dust and fine trash removal.
- Precision doffing rollers deliver a uniform batt to the feedworks.
- Massive solid steel feed roller and feed plate firmly hold and present the cotton to the saw cylinder for smooth combing action.
- Dynamically balanced saw and brush cylinders have heavy-duty pillow block bearings for stability and long, trouble-free operation.
- Massive steel grid bars remove trash without deflecting. Air wash keeps trash away from clean cotton.
- Positive brush doffing.

Optional Items

Monorail System allows easy removal of brush and saw cylinders.

The Lummus Modulating Feed Control maintains the correct combing ratio automatically by electronically regulating the speed of the lint cleaner feedworks to match the ginning rate. This results in far greater productivity than fixed-rate lint cleaner feedworks, which fail to adjust to ginning fluctuations, resulting in lower cleaning efficiency and greater fiber loss.



Tandem Series 2000™ Model 108 Lint Cleaners (shown with optional Modulating Feed Control)

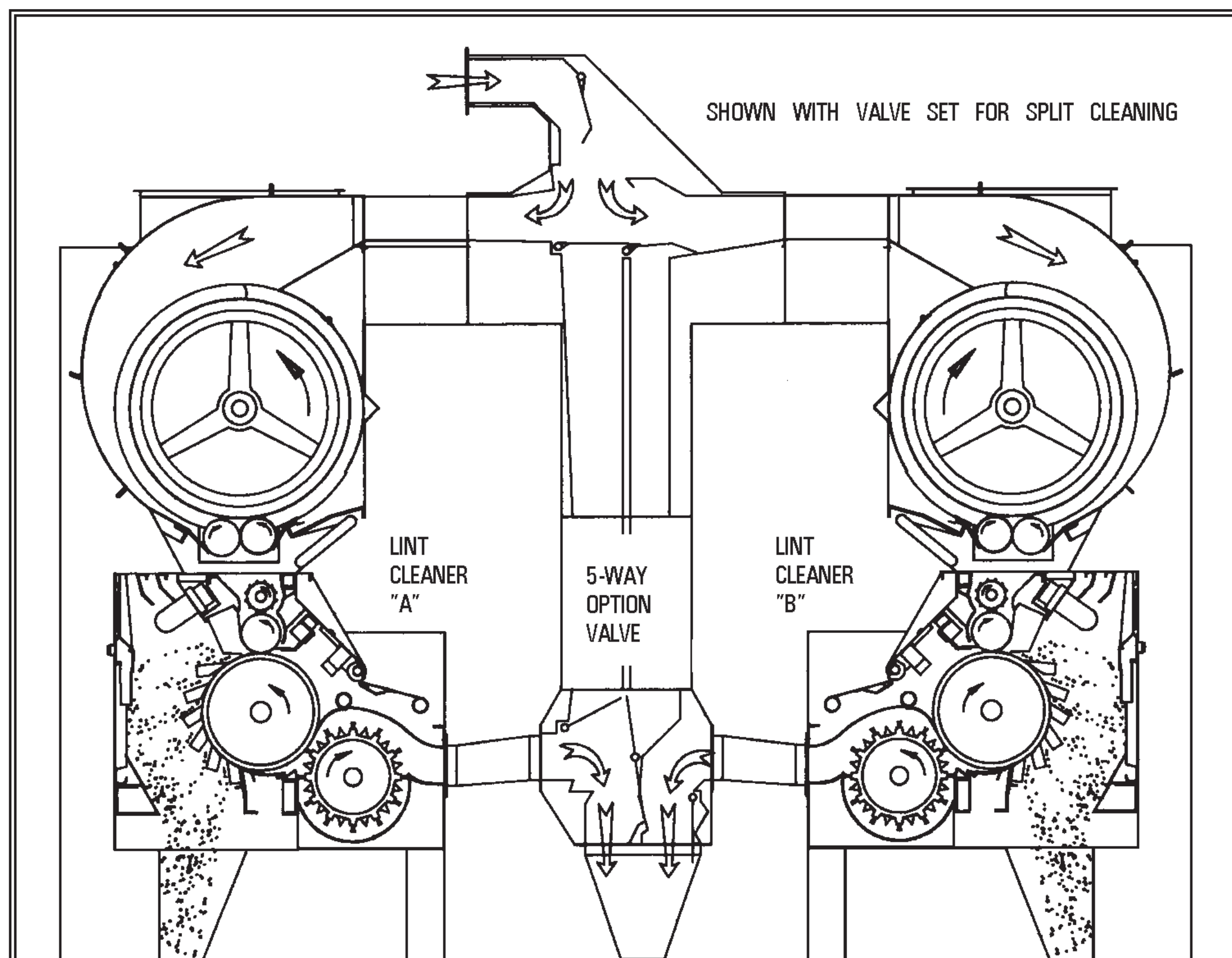

Tandem Lint Cleaners with Five-Way Option Valve (showing Split Cleaning Option)



Physical Address: 225 Bourne Boulevard • Savannah, Georgia 31408-9586 USA
Mailing Address: P. O. Box 929 • Pooler, Georgia 31322-0929 USA
Phone: (912) 447-9000 • Fax: (912) 447-9250
Toll Free (USA Only): 1-800-4LUMMUS (1-800-458-6687)
Web Site: www.lummus.com • E-mail: lummus.sales@lummus.com



Lummus products described or listed in this publication are illustrative only. Application and use of these products must be in accordance with the applicable codes and regulations and must be arranged and/or provided with covers and other guards where necessary to assure the safety of personnel. Lummus engineers continue to make improvements. All designs, specifications, and ratings are subject to change without notice.