

Inclined Cleaners – Hot Air and Gravity

More options and arrangements produce better system performance.

Lummus Inclined Cleaners offer the ultimate in flexibility to yield the greatest number of cleaning options for all types of seed cotton. As part of a complete system design, these cleaners work effectively with any design of drying system and provide unparalleled throughput.

Features:

- Available in 96", 120", and 144" widths.
- Modular 3-Cylinder Sections allow for multiple cleaner configurations (6-cylinder or 9-cylinder).
- Two styles of cylinder design: Standard (skin-type) Cylinders with replaceable spikes (for most types of seed cotton) or Heavy-Duty (tube-type) Cylinders with longer replaceable spikes (for rougher-harvested seed cotton). All cylinders feature the Lummus exclusive Star-Lobe™ replaceable stub shafts for simplified and lower-cost maintenance.
- Two types of Hot Air Cleaner Inlet Options: Conventional Inlet or Splatter-Back Inlet (either can be oriented for front or rear entry to the machine) – both provide for an even dispersion of the seed cotton and air stream across the width and depth of the cleaner.
- Either cleaner configuration (6-cylinder or 9-cylinder) can also be fitted with a Gravity-Type Inlet and Belly Pan with Trash Conveyor for use in gravity-fed applications.



9-Cylinder Inclined Hot Air Cleaner
(shown with dual Front-Entry Splatter-Back Inlets)

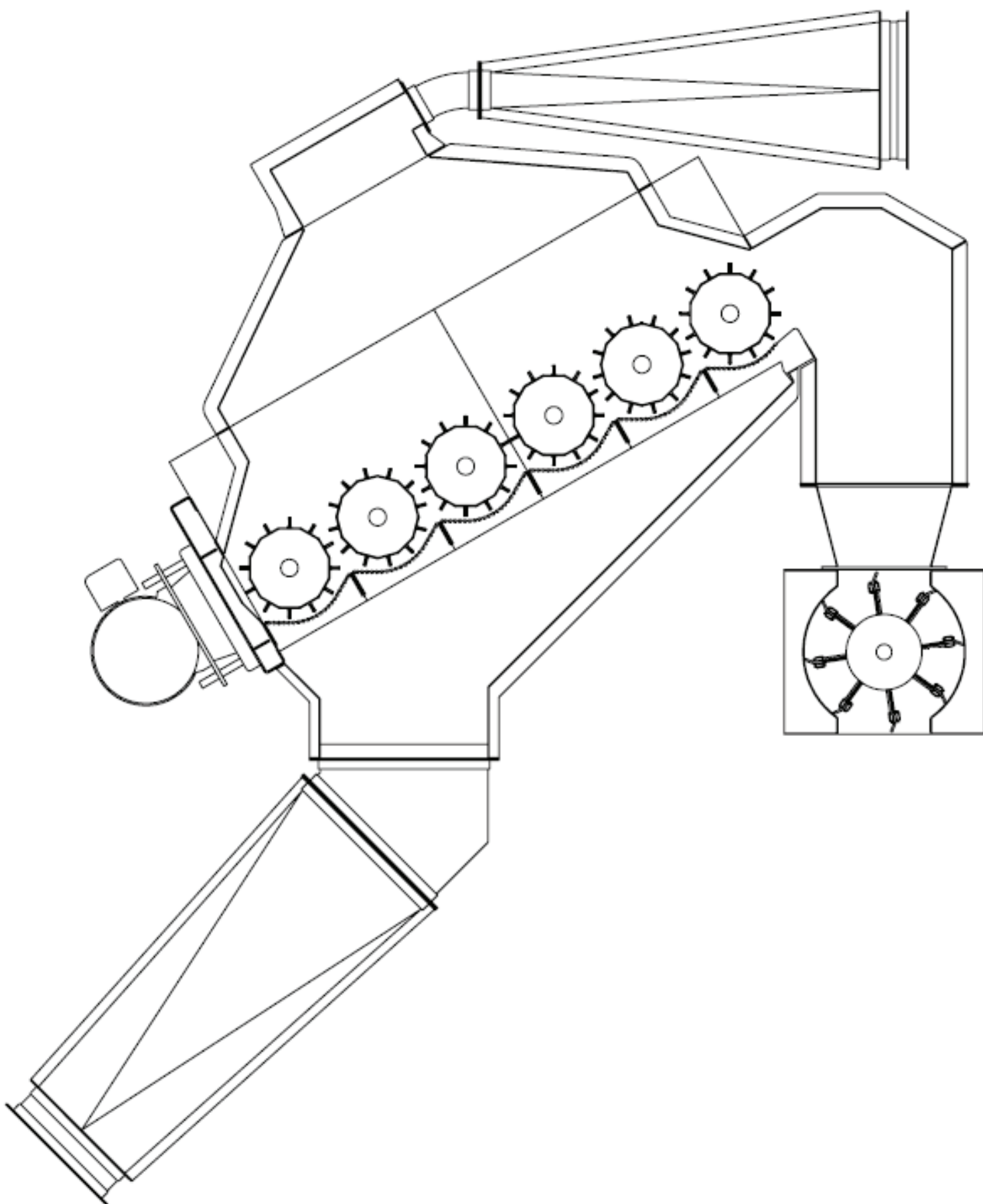

Cross-section of 6-Cylinder Inclined Hot Air Cleaner with Conventional Inlet, Standard Spiked Cylinders, and 22½" diameter Vacuum Wheel

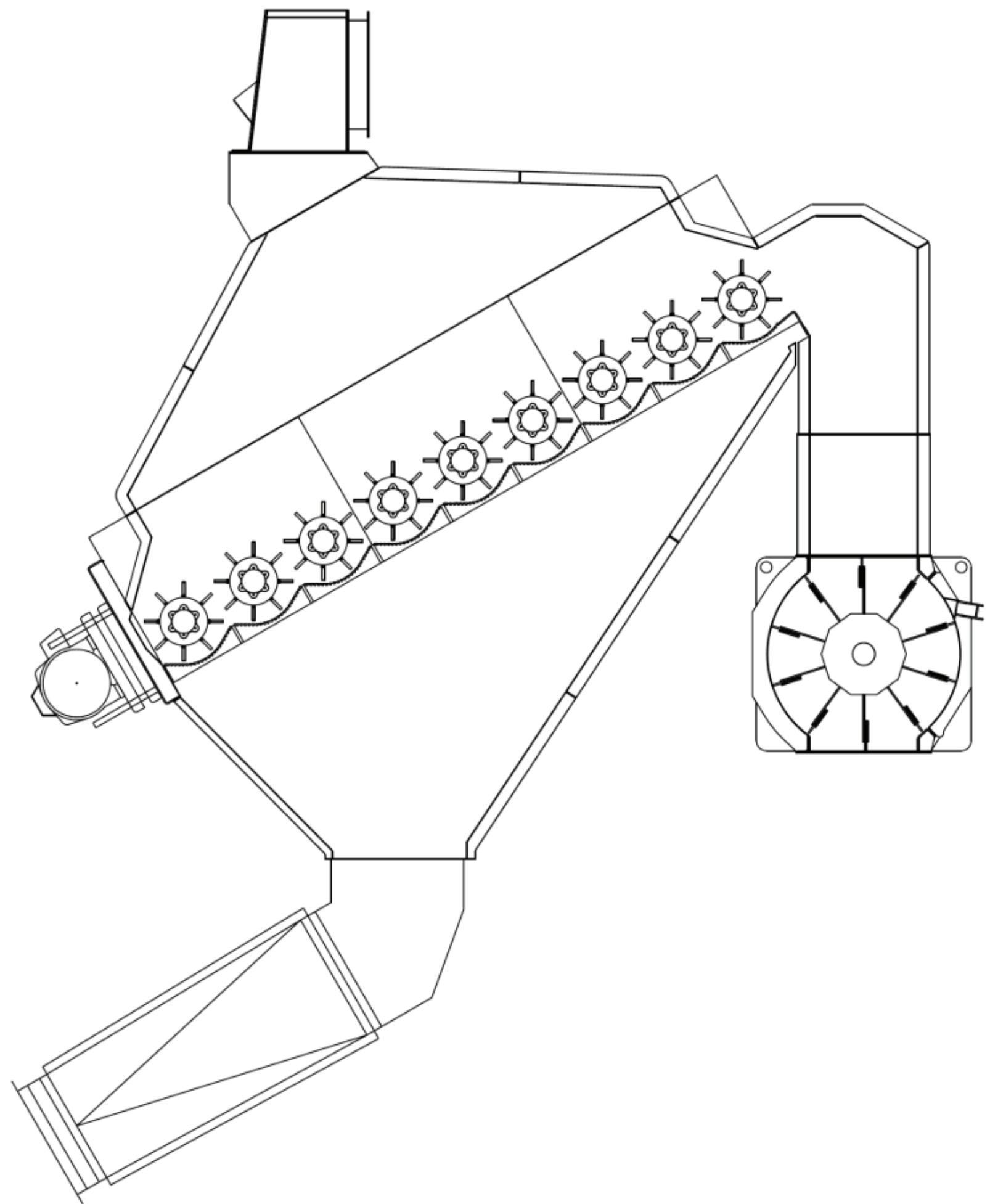

Cross-section of 9-Cylinder Inclined Hot Air Cleaner with Splatter-Back Inlet, Heavy-Duty Spiked Cylinders, and 34" diameter Vacuum Wheel



Physical Address: 225 Bourne Boulevard • Savannah, Georgia 31408-9586 USA
Mailing Address: P. O. Box 929 • Pooler, Georgia 31322-0929 USA
Phone: (912) 447-9000 • Fax: (912) 447-9250
Toll Free (USA Only): **1-800-4LUMMUS** (1-800-458-6687)
Web Site: www.lummus.com • E-mail: lummus.sales@lummus.com

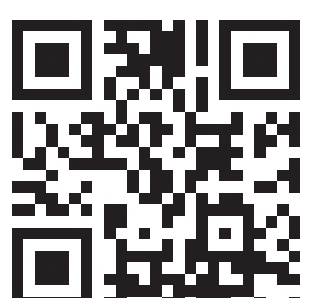

Lummus products described or listed in this publication are illustrative only. Application and use of these products must be in accordance with the applicable codes and regulations and must be arranged and/or provided with covers and other guards where necessary to assure the safety of personnel. Lummus engineers continue to make improvements. All designs, specifications, and ratings are subject to change without notice.